

ECO NO.	DATE	REV.	REVISION RECORD	INIT.	DR. BY
4231	1/14	A	D. 47 WAS 47; ADDED GROUND.		CEU
4574	5/24	B	ADDED (N/O) TO WATER TEMP SWITCH ADDED (N/C) TO OIL PRESS. SWITCH		JEC
4743	12/5	C	UPDATED WIRING FOR: BAT. CHARGER RECTIFIER, RELAY, CURRENT TRANS. REMOVED FUSE 2 RESISTOR, CIRCUIT BREAKER, FUSE, CONN., CAP., & AMP. OUTPUT		TSM
4819	2/14	D	CHANGE IN TITLE: 3.0/3.5 FROM 4.2/3.5		LLM
4885	2/19	E	ADDED RESISTOR TO BATTERY CHARGER		JCH
5084	1/1	F	ADDED JUMPER #10 WHITE/GREEN		RM
5187	2/1	G	UPDATED BATTERY CHARGING CIRCUIT ADD EXHAUST TEMP SWITCH & 35A C.B. ADDED GROUND WIRE TO STARTER.		TSM

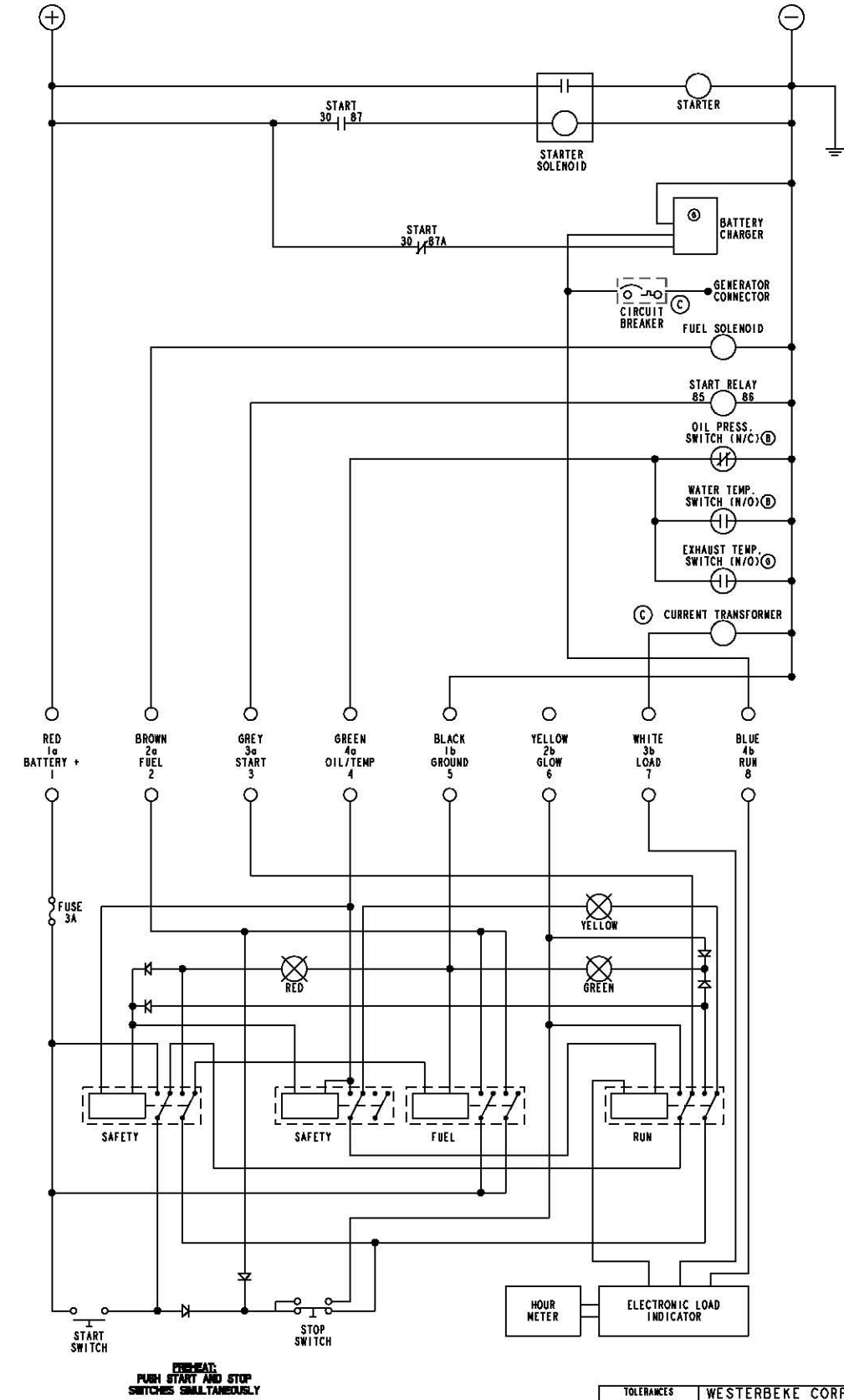
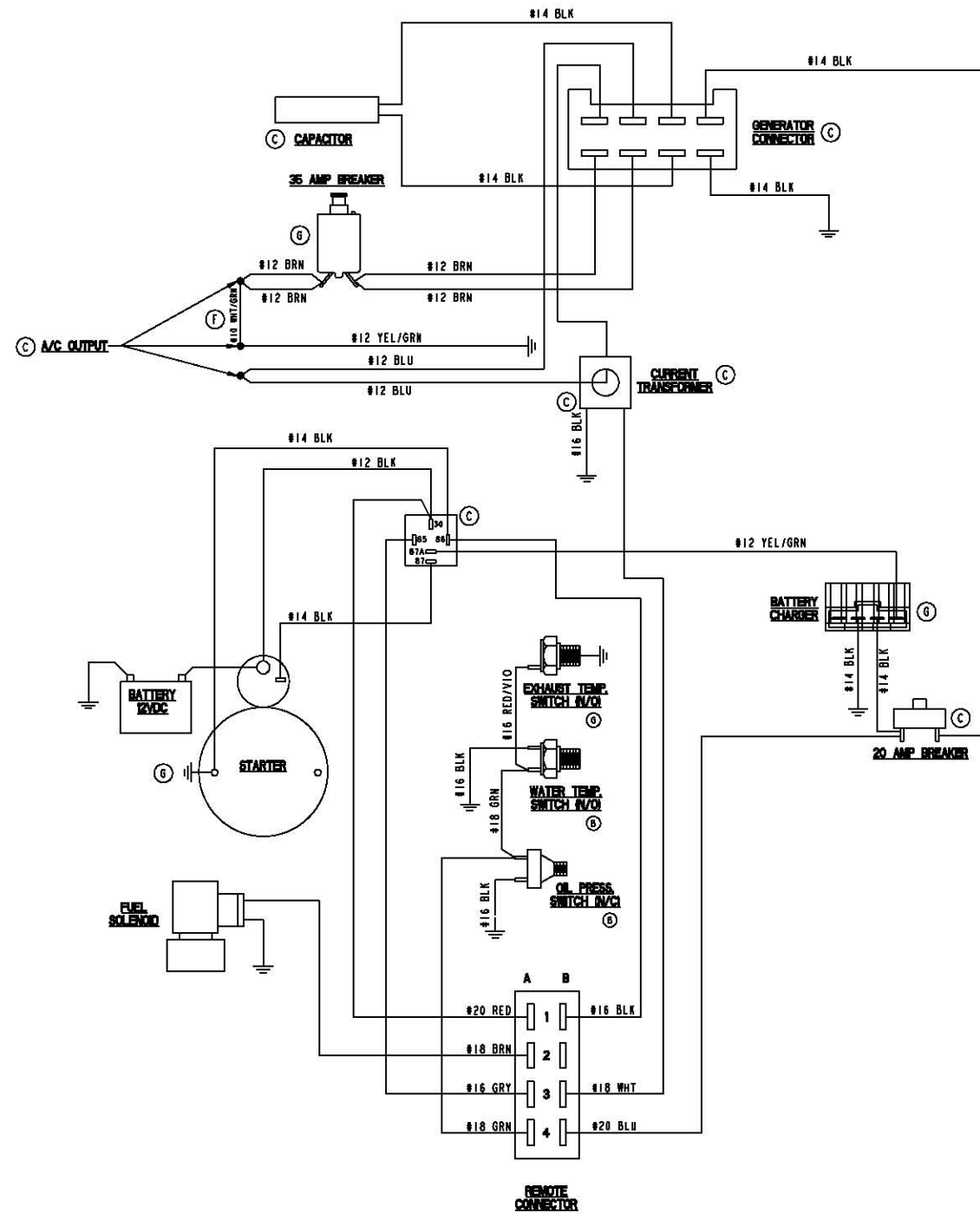

TOLERANCES		WESTERBEKE CORPORATION	
INCHES	MILLIMETERS	AVON MA. 02322	
FRACTIONS		WIRING DIAGRAM / SCHEMATIC	
DECIMALS		3.0KW/3.5KW BCDT ©	
ANGLES		DATE	02/18/91
THROUS		DESIGNED BY	
		DRAWN BY	
		CHECKED BY	
		DATE	
		SCALE	NONE
		SIZE	A
		REV.	44163 G
		DRG. NO.	44163 G